

Town of Shellbrook  
Bylaw No. 2015-06

A Bylaw of the Town of Shellbrook to Provide for Weeping Tile  
Discharge Standards:

The Mayor and Council of the Town of Shellbrook in the Province of Saskatchewan, in open meeting, hereby enact as follows:

**PART I - INTERPRETATION**

1. This bylaw may be cited as the Weeping Tile Water Discharge Bylaw.
2. **Application**

This Bylaw shall apply to all residential dwellings and dwelling units within the Town of Shellbrook which have been constructed as of the date of final passing of this bylaw.

3. **Definitions**

- a) "Approved " means permitted, inspected or approved by the governmental agency or other authority having jurisdiction over the subject matter to which the approval relates;
- b) "Council" means the municipal council of the Town of Shellbrook;
- c) "Dwelling" means any structure used or occupied or intended for supporting or sheltering any residential use;
- d) "Owner" means a person who has any right , title, estate, or interest in land or improvements other than that of a mere occupant, tenant, or mortgagee;
- e) "Weeping Tile Water Discharge System" means a system including sump, sump pump and related piping used to convey water collected by drainage in weeping tile, eaves trough, roof spouts or foundation drain;
- f) "Town" means Town of Shellbrook;
- g) "Building Inspector" means the person appointed by Council, to perform the duties of this bylaw or any other bylaw or resolution of council.

## **PART II - STANDARDS**

4. The owner of every newly constructed dwelling shall install a Weeping Tile Water Discharge System such as to allow discharge to the surface at the front of the building in such a way that it drains off the property.
5. The Weeping Tile Water Discharge System shall be installed by the owner in such a manner as to comply with all town bylaws and policies and other applicable regulatory authorities and without causing excessive ponding or icing on public or private property.
6. The costs associated with installing a Weeping Tile Discharge System will be the sole responsibility of the owner.
7. The Weeping Tile Discharge System shall be inspected and approved by the Building Inspector upon giving 24 hours' notice.
8. The standards for a Weeping Tile Water Discharge System as set forth in Schedule "A" to this Bylaw shall be the standards for the Town of Shellbrook, and the said Schedule "A" is hereby enacted and adopted as a part of this Bylaw.

## **PART III - ENFORCEMENT**

9. Enforcement of Bylaws

The administration and enforcement of this Bylaw is hereby delegated to the Town Building Inspector and the Town Administrator.

## **PART IV – OFFENCES and PENALTIES**

10. Any person in violation of a provision of this Bylaw shall be guilty of an offence and shall be liable upon summary conviction to a fine of not less than \$500.00 but not exceeding:
  - a) \$10,000.00 in the case of an individual; or
  - b) \$25,000.00 in the case of a corporation.

## **PART V – SEVERABILITY**

11. If a court of competent jurisdiction should declare any section or part of a section of this Bylaw to be invalid, such section or part of a section shall not be constructed as having persuaded or influenced the Council to pass the remainder of the bylaw, and it is hereby

declared that the remainder of the Bylaw shall be valid and shall remain in force and effect.

This Bylaw shall come into effect on the date of final approval by the Council of the Town of Shellbrook.

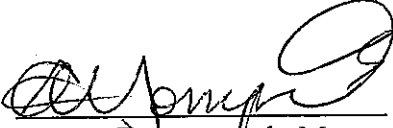

  
George Tomporowski, Mayor

  
Kelly Hoare, Administrator

Certified a True and Accurate Copy  
of Bylaw 2015-06 passed by resolution  
of Council this 8<sup>th</sup> Day of June, 2015.

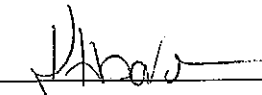
  
\_\_\_\_\_  
Kelly Hoare

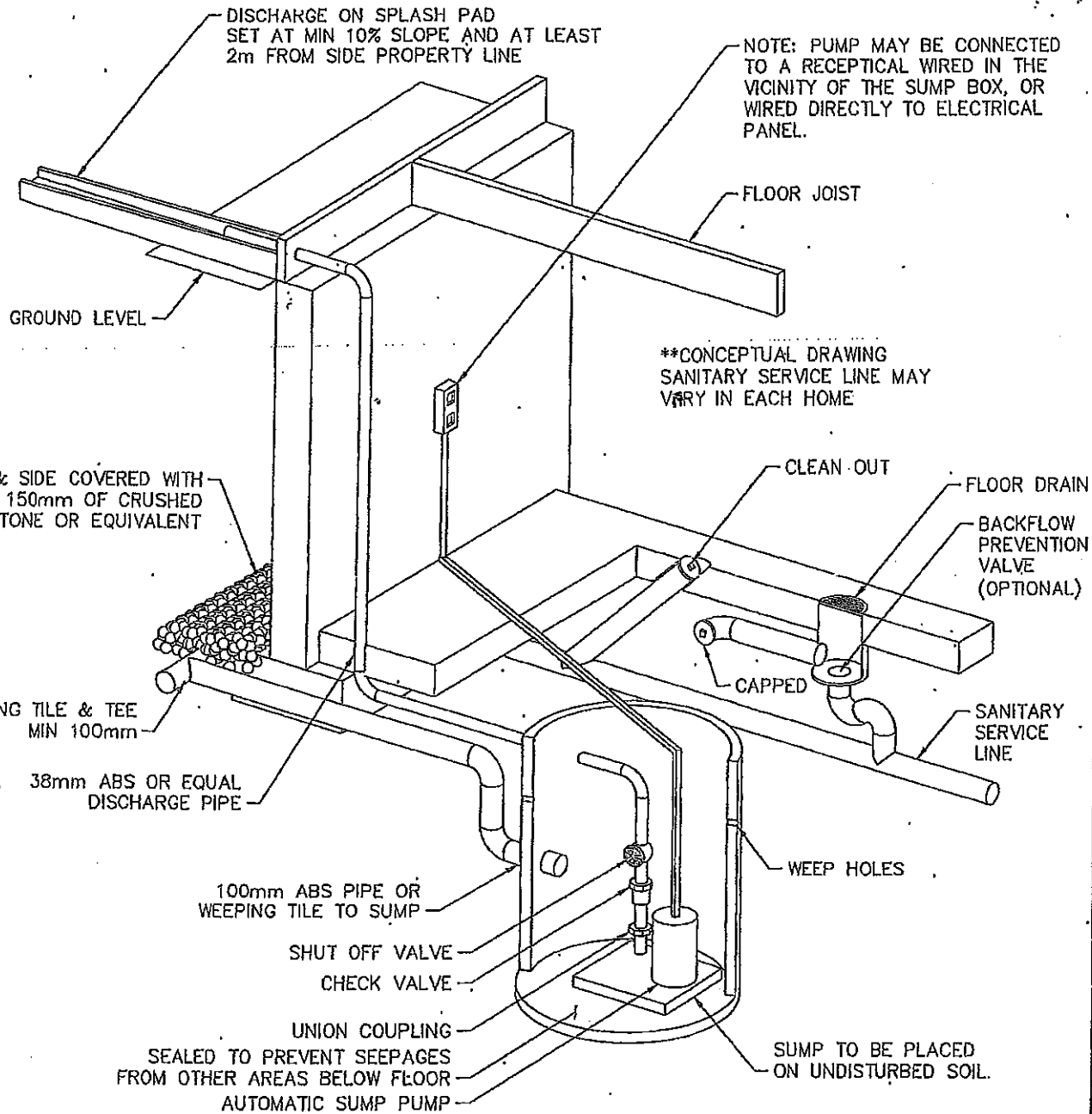

DISCHARGE ON SPLASH PAD  
SET AT MIN 10% SLOPE AND AT LEAST  
2m FROM SIDE PROPERTY LINE

NOTE: PUMP MAY BE CONNECTED  
TO A RECEPTAL WIRED IN THE  
VICINITY OF THE SUMP BOX, OR  
WIRED DIRECTLY TO ELECTRICAL  
PANEL.

FLOOR JOIST

GROUND LEVEL

\*\*CONCEPTUAL DRAWING  
SANITARY SERVICE LINE MAY  
VARY IN EACH HOME

TOP & SIDE COVERED WITH  
MIN. 150mm OF CRUSHED  
STONE OR EQUIVALENT

CLEAN-OUT

FLOOR DRAIN

BACKFLOW  
PREVENTION  
VALVE  
(OPTIONAL)

WEeping TILE & TEE  
MIN 100mm

CAPPED

SANITARY  
SERVICE  
LINE

38mm ABS OR EQUAL  
DISCHARGE PIPE

WEEP HOLES

100mm ABS PIPE OR  
WEeping TILE TO SUMP

SHUT OFF VALVE

CHECK VALVE

UNION COUPLING  
SEALED TO PREVENT SEEPAGES  
FROM OTHER AREAS BELOW FLOOR  
AUTOMATIC SUMP PUMP

SUMP TO BE PLACED  
ON UNDISTURBED SOIL.

CODE REFERENCE ON SUMP:  
NATIONAL BUILDING CODE SECTION 9.14.2  
FOUNDATION DRAINAGE  
9.14.5.2 SUMP PITS

SUMP PIT MAY BE CONSTRUCTED OF:  
A) CONCRETE  
B) CORROSION RESISTANT STEEL  
C) PLASTIC

WHERE A SUMP PIT IS PROVIDED IT SHALL BE:  
A) NOT LESS THAN 750mm DEEP.  
B) NOT LESS THAN 0.25sq.m IN AREA, AND  
C) PROVIDED WITH A COVER.

REVISIONS		SUMP WITH PUMPED DISCHARGE TO SURFACE	APPROVED	
1			GENERAL MANAGER	P. ENG.
2			ENGINEER	
3			ENGINEER	
DRAWN BY _____ DATE _____		SCALES: HOR. _____ NTS _____		
CHECKED BY _____ DATE _____		PLAN NO. _____		